

EHC Fluid Conditioning



Systems reduce acid and remove water and particles from synthetic EHC fluids.

HILCO is not a new player to EHC fluid conditioning. The fluids used in the high pressure electrohydraulic control (EHC) systems in steam turbines present a unique set of problems. These fluids, typically a fire-resistant, synthetic phosphate ester, can become contaminated with high acid levels as a result of water in the system (hydrolysis).

For many years, HILCO has been providing systems to treat EHC fluids. These systems can provide treatment in a number of ways by utilizing HILCO's Selexsorb, fuller's earth, activated alumina, or ion exchange cartridges.

HILCO always recommends contacting the fluid manufacturer when considering new conditioning applications or changing the current conditioning method.

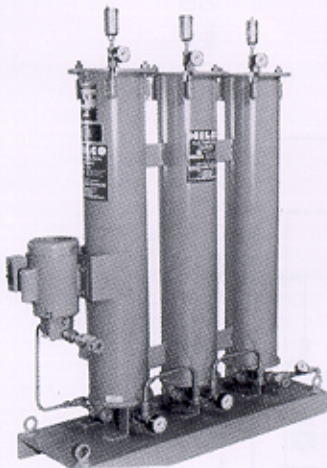

Fluid Conditioning with Selexsorb

The system to the left is a two-stage system with pump and motor. The first stage is comprised of four HILCO Selexsorb GT cartridges (the first two housings). The second stage contains HILCO's Dryer cartridge, which removes all free water and particulate down to 3 micron absolute. Using four HILCO ST718-00-03ZXCO cartridges, up to 58 pounds of Selexsorb media can be housed in this system. HILCO manufactures 718 cartridge systems that can take up to 250 pounds of media.

This same system can be used with HILCO's fuller's earth (HT718) and activated alumina (AT718) cartridges.

Model	Capacity No. of ST718-00-03ZXCO/ Total Media Weight
26718-530401110	2 cartridges/29 lbs.
26718-530401109	4 cartridges/58 lbs.
46718-530401107	6 cartridges/87 lbs.

High Capacity Housings

HILCO 1119 cartridges provide high media capacity: each cartridge contains up to 36 pounds. This is almost four times that of competitive 718 cartridges. To the customer, this means fewer changeouts and less cost per pound of media.

The system to the right is a single-stage system which contains two 1119 cartridges for up to 72 pounds of media.

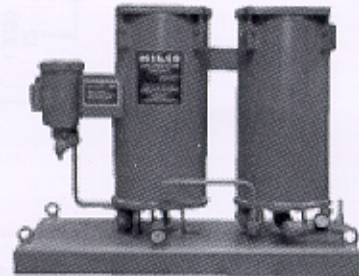

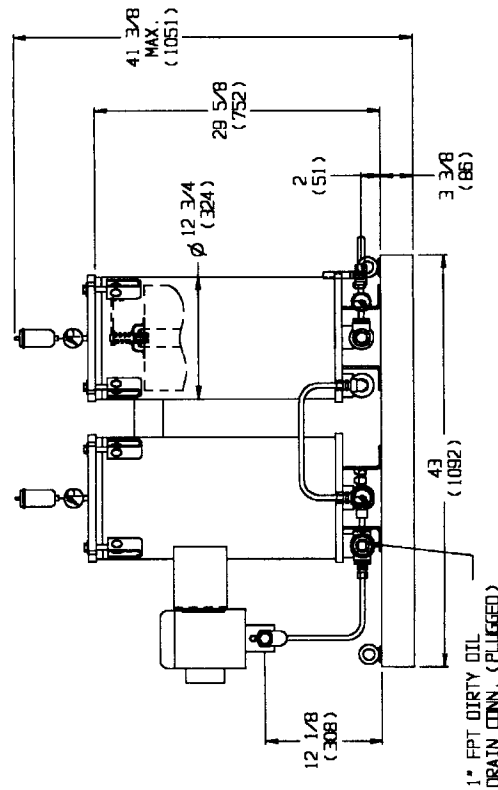
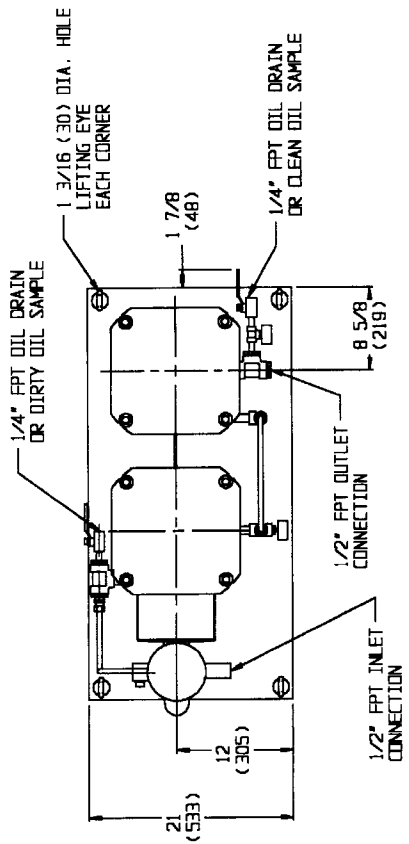

1119 SYSTEM

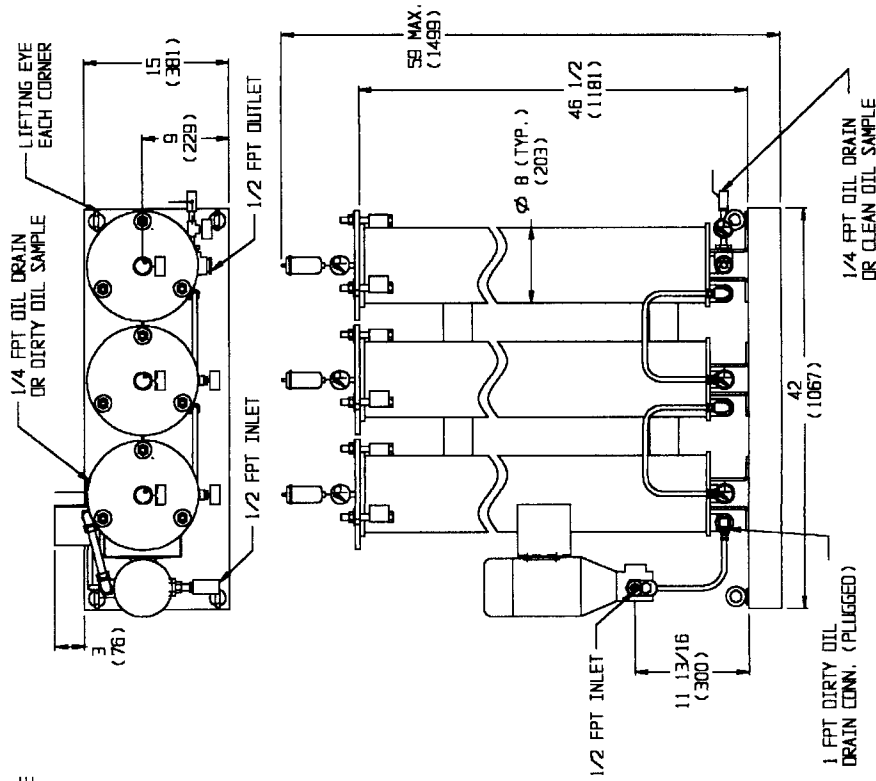

718 SYSTEM

The Hilliard Corporation 100 West Fourth Street, Elmira, NY 14902 U.S.A.
 Phone: (607) 733-7121, Fax: (607) 737-1108, <http://www.hilliardcorp.com>

