

DUST COLLECTOR ELEMENTS

DUST COLLECTORS

Filtration Systems makes a wide range of dust collector cartridges to fit all popular makes and models of equipment. The cartridges feature heavy-duty construction to withstand rigorous use.

We offer three grades of media, to match your application requirements.

Our standard media is an 80:20 Blend of cellulose and synthetic fibers, with a hydrophobic binder, for excellent moisture resistance. There is also a flame-retardant version available.

Our Spunbonded Polyester media has unsurpassed strength, making it an excellent choice for back-pulse applications, such as powder-coating, etc. Also available with an aluminized coating.

Our Nanofiber Laminate is rated at MERV 14, right out of the box, making it an ideal media for gas turbine filtration units.



Filtration Systems' Computer Controlled Pleaters make consistent high-quality products.

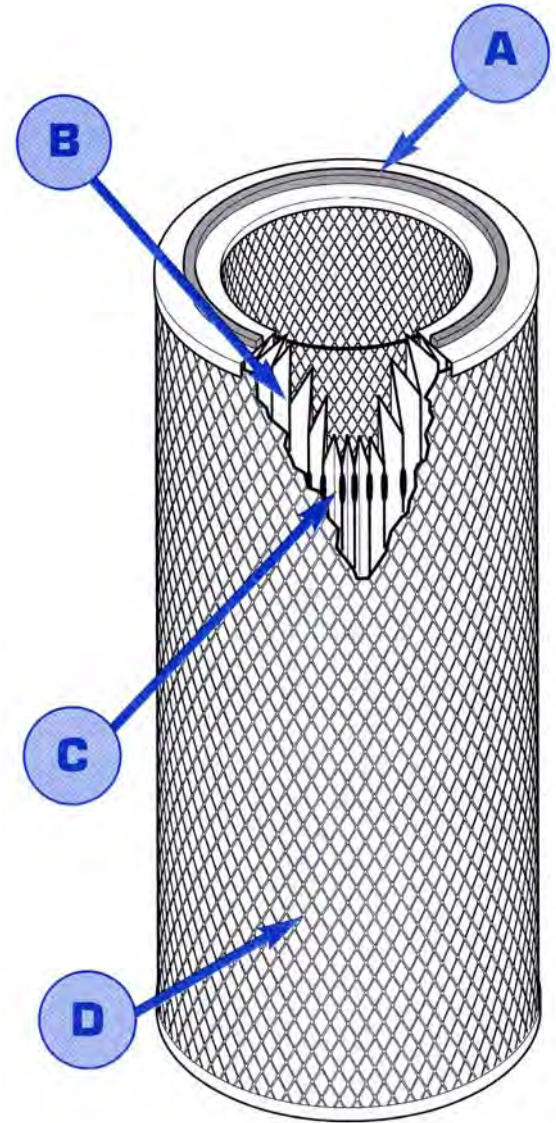

A Our gasket material is specifically formulated to maintain sealing integrity. It has excellent compression-set resistance, <2% per ASTM D3574

B All of Filtration Systems' media are hydrophobic, for better dimensional stability in high humidity or outdoor installations. They are also washable for longer service life and better value.

C Our blade-type Computer Controlled Pleaters make straight, sharp pleats for better air flow and back-pulse performance

D The pleat pack is protected with a corrosion-resistant metal outer cage. The extra-large diamond pattern has 77% open area, for better flow and unloading characteristics.



DUST COLLECTOR MEDIA

Filtration Systems' "DC" paper media has a high polyester content, for higher removal efficiency and added strength. It has a very high Mullen Burst rating, for excellent resistance to abrasion and rupture. Its water repellent binder improves performance in wet, rainy conditions, and can be washed for repeated use.

Our "DCP" spunbonded media is 100% polyester. It is an air laid product, so it has no binders. It has high filtration efficiency, and its fine fiber diameter gives it excellent permeability, for good flow characteristics. It is extremely strong and has very long service life, even in demanding back-pulse applications.

Our new "DCL" nanofiber technology features a very fine layer of micro-fibers on the surface of the media. This layer not only provides very high initial filtration efficiencies, but has excellent release properties, giving it extended service life in self-cleaning installations.



80:20 Blended Media

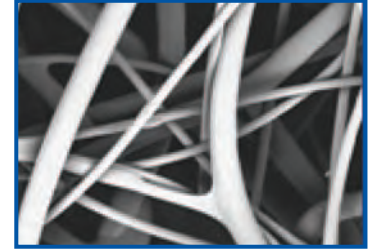

Spunbonded Polyester Media

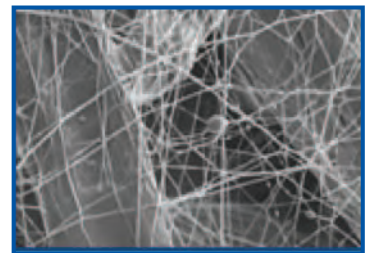

Nanofiber Laminated Media

INDEPENDENT TEST DATA

Tests run per ASHRAE 52.1-1992 on a DC-1226-O/O taken at random from stock

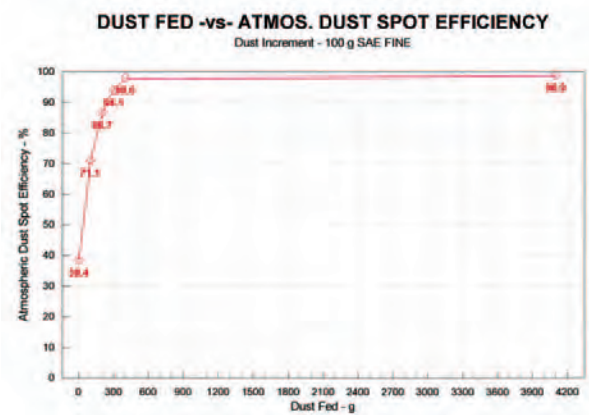
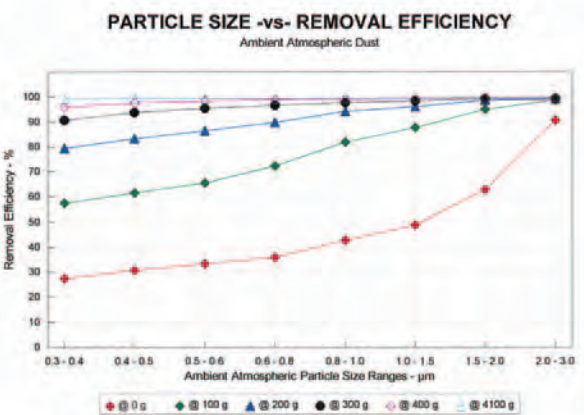
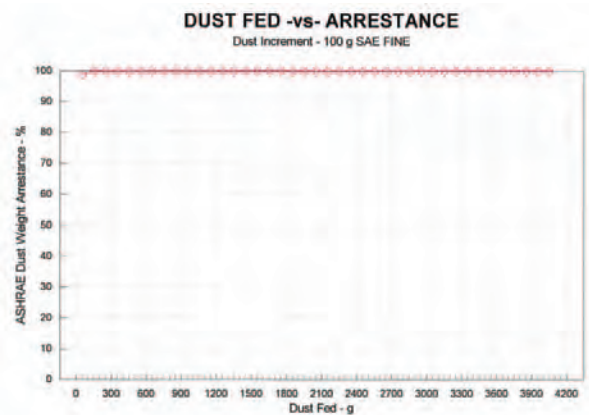
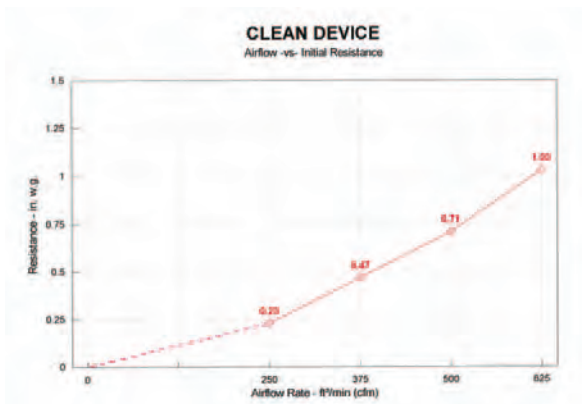

Nomenclature Chart:

DCP-1226-O/CB-FR-NS

DUST COLLECTOR

MEDIA	
(blank)	80:20 Blended Media
P	Spunbonded Polyester
L	Nanofiber Laminate
AP	Aluminized Polyester

OUTSIDE DIAMETER	
08	7.90" Dia.
09	9.00" Dia.
12	12.75" Dia.
14	13.84" Dia.
16	16.05" Dia.
18	17.60" Dia.

SPECIAL CONSTRUCTION <i>(can use more than one)</i>	
1	1.19" Center Hole
FR	Flame Retardant
NS	No Outer Screen
GB	Glue Beads
10K	Farr-Style*
WS	Wheelabrator-style*
CONE	Conical Shape

END CAPS	
O	Open End
C	Closed End
CB	Closed with Bolt Hole

LENGTH
16"
22"
26"
28"
29"
30"
32"
36"



ISO 9001:2000



LOCAL DISTRIBUTOR:

W229 N591 Foster Court • Waukesha, WI 53186
 Phone: 262.548.6210 • FAX: 262.548.6239

Visit our website at www.filtersys.com or
 email us at sales@filtersys.com

*Tradenames are for reference only.
 Filtration Systems reserves the right to alter
 any published data without notice.*

PRINTED IN USA